



## Worldwide Headquarters

1025 Conroy Place, Easton, PA 18040

United States of America

Phone: +1-610-250-5800

Fax: +1-610-250-2700

Toll Free: 1-888-TORCUP-1

E-mail: sales@torcup.com

Website: www.torcup.com

# Torque Wrench Power Pump EP500

Operating & Maintenance Instructions  
For 1.125 hp 115V And 230V Power Pump



Version 2  
June 2009

## WARNING

**IMPORTANT SAFETY INFORMATION ENCLOSED.  
READ THIS MANUAL BEFORE OPERATION.  
IT IS THE RESPONSIBILITY OF THE EMPLOYER TO PLACE THE INFORMATION IN THIS MANUAL INTO  
THE HANDS OF THE OPERATOR.  
FAILURE TO OBSERVE THE FOLLOWING WARNINGS COULD RESULT IN INJURY.**

The use of other than genuine TorcUP replacement parts may result in safety hazards, decreased tool performance, and increased maintenance, and may invalidate all warranties.

Repairs should be made only by authorized personnel. Consult your nearest TorcUP Authorized Service Center. Refer all communications to the nearest TorcUP Office or Distributor.

## WARNING

For Technical Support and Information Contact:  
TorcUP, Inc.  
1025 Conroy Place, Easton, PA 18040  
Toll Free: (888) TORCUP-1 Fax: (610) 250-2700  
E-mail: info@torcup.com

## FAILURE TO OBSERVE THE FOLLOWING WARNINGS COULD RESULT IN INJURY

- Keep hands, loose clothing and long hair away from the reaction arm and working area during operation. Do not attempt to support the tool with your hands during operation.
- This tool will exert a strong reaction force. Use proper mechanical support and correct reaction arm positioning to control these forces. Do not position the reaction arm so that it tilts the tool off the axis of the bolt and never use the swivel inlets as a reaction stop.

Avoid sharp bends and kinks that will cause severe back-up pressure in hoses and lead to premature hose failure.

- Use accessories recommended by TorcUP.
- Use only impact sockets and accessories. Do not use hand (chrome) sockets or accessories.
- Use only sockets and accessories that correctly fit the bolt or nut and function without tilting the tool off the axis of the bolt.
- This tool is not designed for working in explosive atmospheres

Always wear eye protection when operating or performing maintenance on this tool.



Always wear ear protection when operating this tool.



Keep body stance balanced and firm. Do not overreach when operating this tool.



Operate at 10,000 psig (681bar) maximum pressure.

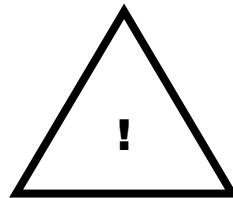

Do not use damaged, frayed or deteriorated hydraulic hoses and fittings.



Always turn off the pump and disconnect the power before installing, removing, or adjusting any accessory on this tool, or before performing any maintenance on this tool.



Do not carry the tool by the hose.



The Torque Reaction Arm must be positioned against a positive stop. Do not use the Arm as a dead handle. Take all precautions to make certain the operator's hand cannot be pinched between the Arm and a solid object.



## NOTICE

**SAVE THESE INSTRUCTIONS. DO NOT DESTROY.**

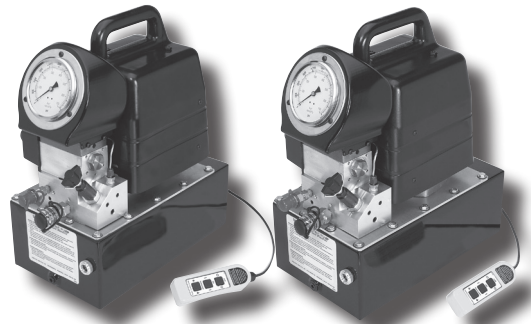
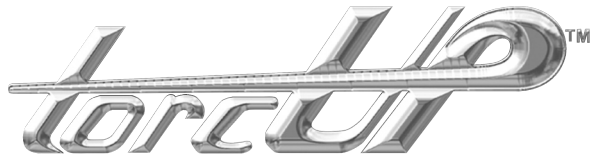

# EP500 & EP1000 TORQUE PUMPS

Rev. - A

Date - 0709

## CONTENTS

*Receiving Instructions and Warranty Statement* ..... 1

*Safe and Correct Use* ..... 2-3

*Technical Specifications* ..... 4

*Working Pressure* ..... 4

*Install Vent Plug* ..... 4

*Adding Oil* ..... 4

*Install Hydraulic Connections* ..... 5

*Electrical* ..... 5

*Connecting Hydraulic Tools* ..... 5

*Starting the Pump for the First Time* ..... 5

*Pump Mounting* ..... 6

*Control Valves* ..... 6

*Power Control Switches* ..... 6

*Pressure Torque Setting* ..... 7

*After Completing the Job* ..... 7

*Periodic Maintenance* ..... 7

*Maintain Oil Level* ..... 8

*Clean Oil Intake Screen* ..... 8

*Flushing the Pump* ..... 8

*Problem / Cause - Solutions* ..... 9

**- Note -**

TorcUP has taken every care in preparing this Operational Manual that is intended as a technical guideline only. TorcUP accepts no liability in relation to any use or reliance made of any information in this Operational Manual. All information, illustrations and specifications in this Operational Manual are based on the latest information available at the time of publication. The right is reserved to make changes at any time without notice. Equipment operators and installers shall be responsible for ensuring that a safe working environment and safe systems of work are in place before operating the equipment.

## EP Torque Pumps



**EP500**



**EP1000**

### **IMPORTANT - READ CAREFULLY**

This manual contains important information for the correct installation, operation and maintenance of this equipment. All persons involved in the installation, operation and maintenance of this equipment must be thoroughly familiar with the contents of this manual. To safeguard against the possibility of personal injury or property damage, follow the recommendations and instructions of this manual. Keep this manual for reference.

### **WARRANTY STATEMENT**

TorcUP products are warranted to be free of defects in materials and workmanship under normal use for as long as the original purchaser owns them, subject to the guidelines and limitations listed. This warranty does not cover: *normal wear & tear, cosmetic items, abuse, overloading, alterations, improper fluid, or use in a manner for which they are not intended*. If the customer believes a product is defective, the product must be delivered, or shipped freight prepaid, to the nearest TorcUP Authorized Service Center for evaluation and repair.

### **1.0 RECEIVING INSTRUCTIONS**

Important! Make sure to inspect all of the components for shipping damage. If damage is found, notify carrier at once. Shipping damage will not be covered by warranty. The carrier is responsible for all loss associated with shipping damage.

## **2.0 SAFETY**

Make sure to read the instructions, warnings and precautions carefully. Follow any recommended safety precautions to avoid personal injury or damage to the unit. TorcUP cannot be responsible for any damage or injury from unsafe use, lack of maintenance or incorrect operation. In the event any questions or concerns arise, contact TorcUP or a local Distributor for clarification.

The pump's maximum working pressure is 10,000 PSI (700kg/cm<sup>2</sup>). Make sure that all hydraulic equipment such as rams, hoses, etc. used with this pump are rated at 10,000 PSI (700kg/cm<sup>2</sup>) operating pressure.



If you have never been trained on high-pressure hydraulic safety, consult your distributor or service center for a free TorcUP Hydraulic Safety Course.

Failure to comply with the following cautions and warnings could cause equipment damage, property damage or personal injury.

**DANGER** is only used when your action or lack of action may cause serious injury or even death.

**WARNING** indicates a potential danger that requires correct procedures or practices to avoid personal injury.

**CAUTION** is used to indicate correct operating or maintenance procedures and practices to prevent damage to, or destruction of equipment, or other property.

**WARNING:** Wear proper personal protective gear when operating hydraulic equipment.

**DANGER:** To avoid personal injury, keep hands and feet away from cylinder and work-piece during operation.

**WARNING:** Do not exceed equipment ratings. Overloading causes equipment failure and possible personal injury. The wrenches are designed for a maximum pressure of 10,000 PSI (700kg/cm<sup>2</sup>). Never set the relief valve to a higher pressure than the maximum rated pressure of the pump. Higher settings may result in equipment damage and/or personal injury.

**WARNING:** The system operating pressure must not exceed the pressure rating of the lowest rated component in the system. Install pressure gauges in the system to monitor operating pressure. It is your window to what is happening in the system.

**CAUTION:** Avoid damaging hydraulic hose. Avoid sharp bends and kinks when routing hydraulic hoses. Using a bent or kinked hose will cause severe back-pressure. Sharp bends and kinks will internally damage the hose, leading to premature hose failure.

Do not drop heavy objects on hose. A sharp impact may cause internal damage to hose wire strands. Applying pressure to a damaged hose may cause it to rupture.

**IMPORTANT:** Do not lift hydraulic equipment by the hose or swivel couplers. Use the carrying handle or other means of safe transport.

**CAUTION:** Keep hydraulic equipment away from flames and heat. Excessive heat will soften seals, resulting in fluid leaks. Heat also weakens hose materials. For optimum performance do not expose equipment to temperatures of 65° C (170° F) or higher. Protect hoses and cylinders from weld spatter.

**DANGER:** Do not handle pressurized hoses. Escaping oil under pressure can penetrate the skin, causing serious injury. If oil is injected under the skin, see a doctor immediately.

**DANGER:** Only use hydraulic cylinders in a coupled system. Never use a cylinder with unconnected couplers. If the cylinder becomes severely overloaded, components can fail catastrophically causing severe personal injury or death.

### 3.0 TECHNICAL SPECIFICATIONS

EP500 Electric Torque Wrench		
Voltage	115V	230V
Operating Pressure	10,000 PSI (700kg/cm <sup>2</sup> )	
Electrical Power Source	20 Amps 115V Grounded 50/60 Hz	10 Amps 220V Grounded 50/60 Hz
Motor Rating	1.125 Hp Single Phase 18 Amps @ 10,000 psi (700kg/cm <sup>2</sup> )	1.125 Hp Single Phase 10 Amps @ 10,000 psi (700kg/cm <sup>2</sup> )
Flow Rate	554 cu. in./ min. @ 1,100 psi, 46 cu. in / min. @ 10,000 psi	
Maximum Operating Temperature	170 F - (65 C)	

EP1000 Electric Torque Wrench		
Voltage	115V	230V
Operating Pressure	10,000 PSI (700kg/cm <sup>2</sup> )	
Electrical Power Source	20 Amps 115V Grounded 50/60 Hz	10 Amps 220V Grounded 50/60 Hz
Motor Rating	1.5 Hp Single Phase 18 Amps @ 10,000 psi (700kg/cm <sup>2</sup> )	1.5 Hp Single Phase 10 Amps @ 10,000 psi (700kg/cm <sup>2</sup> )
Flow Rate	575 cu. in./ min. @ 1,100 psi, 55 cu. in / min. @ 10,000 psi	
Maximum Operating Temperature	170 F - (65 C)	

### 4.0 WORKING PRESSURE

The pump's maximum working pressure is 10,000 PSI (700kg/cm<sup>2</sup>). Make sure that all hydraulic equipment such as rams, hoses, etc. used with this pump are rated at 10,000 PSI (700kg/cm<sup>2</sup>) operating pressure.

### 4.1 INSTALL VENT PLUG

Remove SHIPPING PLUG (A) and install VENT PLUG (B) into cover plate.

### 4.2 ADDING OIL

Remove OIL FILLER CAP (C) and add Torcup Hydraulic Oil into reservoir. Oil level should not exceed 1" from the reservoir cover.

\*As a "rule of thumb" oil should be visual in site window when the unit is powered down and all connected tools or cylinders are retracted.

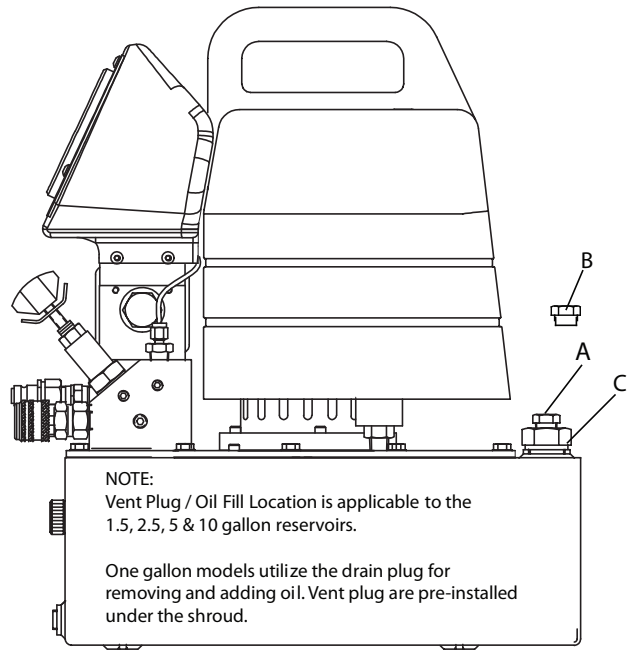

### 4.3 INSTALL HYDRAULIC CONNECTIONS

Use only cylinders, tools, hoses and accessories rated at 10,000 PSI (700kg/cm<sup>2</sup>). Remove the shipping plugs from the ports to connect your coupling(s) or hose(s) to manifold. Use 1.5 wraps of Teflon tape (or suitable thread sealant) on all threads, leaving the first complete thread free of tape to ensure no foreign matter enters the hydraulic circuit.

When making connections with quick disconnect couplings, make sure the couplings are fully engaged. Threaded connections such as fittings, gauges, etc. must be securely tightened and leak free.

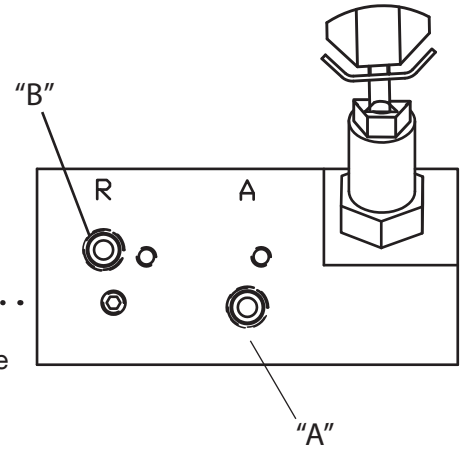

.....  
**WARNING:** Loose or improperly threaded fittings can be potentially dangerous if pressurized; however, severe over tightening can cause premature thread failure. Fittings need to be tightened secure & leak free. Never hold or stand directly in line with any hydraulic connections while pressurizing. Never grab, touch or in any way come in contact with a hydraulic pressure leak. Escaping oil can penetrate the skin and a serious injury can result.  
.....

**CAUTION:** Do not subject the hose to potential hazards such as sharp surfaces, extreme heat or heavy impact. Do not allow the hose to kink or twist. Inspect each hose for wear before it is used.

### 4.4 ELECTRICAL

Check for proper electrical supply before connecting. Be sure the electrical connection is grounded. Check that your power supply agrees with the motor nameplate and/or TorcUP model decal.

**NOTE: MOTOR MAY SPARK. DO NOT OPERATE IN AN EXPLOSIVE ATMOSPHERE OR IN THE PRESENCE OF CONDUCTIVE LIQUIDS.**

1. Do not use a power or extension cord that is damaged or has exposed wires.
2. All single phase motors come equipped with a three prong grounding type plug to fit the proper grounded type electrical outlet. Do not use a two prong ungrounded extension cord as the pump's motor must be grounded.

### 4.5 CONNECTING HYDRAULIC TOOLS

Use only tools, hoses and accessories rated at 10,000 PSI (700kg/cm<sup>2</sup>). When making connections with quick disconnect couplings, make sure the couplings are fully engaged. Threaded connections such as fittings, gauges, etc. must be securely tightened and leak free. Use 1.5 wraps of Teflon tape (or suitable thread sealant) on all threads, leaving the first complete thread free of tape to ensure no foreign matter enters the hydraulic circuit.

### 4.6 STARTING THE PUMP FOR THE FIRST TIME

1. Locate the power switch on shroud and select to the "ON" position. Check for any leaks, repair as needed.
2. Shift pendant to the advance position to advance tool and release to retract tool. Look for movement in tool, check for any leaks, repair as needed.

**CAUTION:** Never operate the pump without tool movement for more than 1 minute. Leaving the valve in the advance or retract position without the tool's piston rod moving will overheat the oil.

**CAUTION:** Never disconnect or connect any hydraulic hoses or fittings without first unloading the tool, then unplug the electrical cord of the pump. Open manual relief valve to assure that the system has been depressurized. View the gauge reading and double check the gauge to assure pressure has been released.

### 4.7 PUMP MOUNTING

Refer to the chart for mounting dimensions to secure the pump to a fixed surface.

	1 gal. (4L)	1.5 gal.(6L)	2.5 gal.(10L)	5 gal. (20L)
<b>A</b>	11	15.13	17	19.6
<b>B</b>	0.56	1.68	2.75	4.69
<b>C</b>	0.56	3.57	4.37	5.03
<b>D</b>	1.16	1.43	1.93	2.93
<b>E</b>	8.19	8.75	9.75	11.75
<b>F</b>	1/4-20unc (4 places)	1/4-20unc (4 places)	1/4-20unc (4 places)	1/4-20unc (4 places)

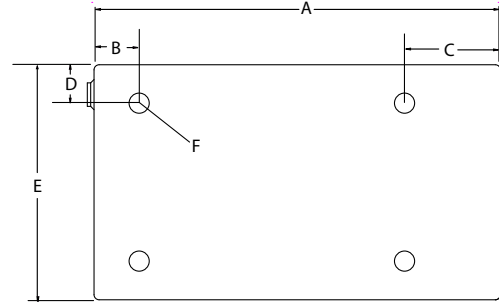

### 5.0 CONTROL VALVES

2-Position – 4 Way Solenoid Valve for Hydraulic Torque Wrenches.

- **To Advance**.....depress the Advance Switch
- **To Retract**.....release advance switch to Retract Tool.

2 Position - 4 Way Solenoid

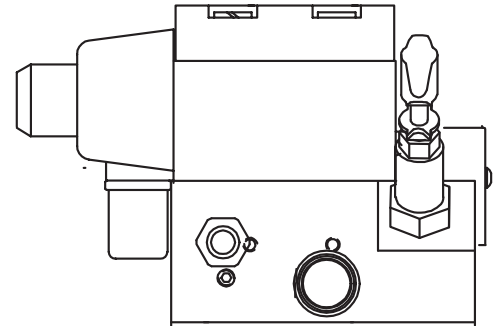

### 5.1 POWER CONTROL SWITCHES

Remote pendant.

Configured with motor control pendant:

**ADVANCE** = Press and hold switch to turn motor on.  
Energizes ADV. Coil.

**ON** = Press switch to turn motor on.

**OFF** = Press switch to turn motor off.

Motor/Valve Control Pendant

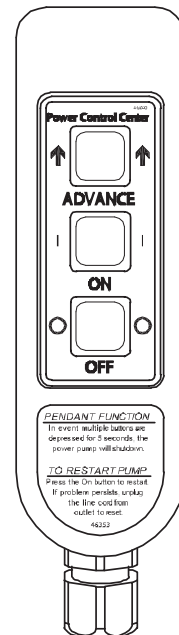

**NOTE:** In the event multiple buttons are depressed for longer than 5 seconds, the unit is programmed to shut down. To restart, you will need to depress the motor “ON” to continue, or unplug / re-plug the unit into power supply, then depress the motor “ON” to continue.



## 5.2 PRESSURE TORQUE SETTING

.....

**WARNING:** Make these adjustments **BEFORE** putting torque wrench on nut or bolt head. The pump pressure setting may be above the pressure needed to provide the required torque for your application. Exceeding required torque will cause equipment damage and may lead to serious personal injury.

.....

1. See torque wrench instructions for amount of pressure required to produce desired torque.
2. Loosen lock nut and back out relief valve to prevent unintended pressure build up.
3. Turn pump on. Press and the “ADVANCE” switch, and read pressure gauge.
4. While holding the switch, turn relief valve in (clockwise) to increase pressure or out (counter-clockwise) to decrease maximum pressure. Repeat until correct pressure is obtained.
5. Tighten lock nut on the relief valve to maintain setting.
6. Run pump several times to test this setting before setting tool on the nut.

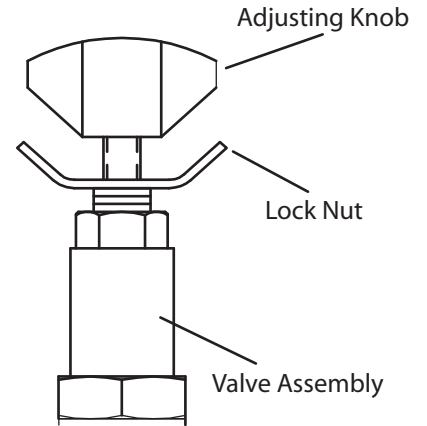

## 5.3 AFTER COMPLETING THE JOB

Before disconnecting hoses, fittings, etc., first be sure the tool is unloaded and retracted, then unplug the power cord. The pump is designed to cycle valve upon power down “off.”

## 6.0 PERIODIC MAINTENANCE

Completely change the hydraulic oil and clean the intake screen and magnet (located in the reservoir) twice a year. If equipped, change the external oil filter twice a year (**Use TorcUP oil only, Model # AO1, 1 gallon**). Change the oil more frequently when used in extremely dusty areas or when the oil has been overheated. Using oil other than TorcUP Brand may void the pump’s warranty.

The following conditions require more frequent oil changes.

- Rigorous duty, where oil temperature may reach 150° F.
- High humidity environment and extreme changes in temperature that can result in condensation inside the reservoir.
- Dirty or dusty environments that may contaminate the oil.
- Frequent connection and disconnection of hydraulic hoses and components.

.....

**WARNING:** The electrical power cord must be disconnected from electrical outlets before performing maintenance or repair procedures.

.....

## **6.1 MAINTAIN OIL LEVEL**

Check hydraulic oil level every 30 hours of operation (sight gauge should be completely covered in oil when all tools are retracted. Add TorcUP oil (Model # AO1 – 1 gallon) when necessary. Oil level should be no more than 1” from top of reservoir plate – with cylinders retracted and motor off.

## **6.2 CLEAN OIL INTAKE SCREEN ONCE A YEAR**

Loosen and remove reservoir plate bolts. Lift pump unit off the reservoir, being careful not to damage the gasket.

### **Applies to 1, 1.5, 2, 2.5 gallon reservoirs:**

Remove the 5 Allen socket head cap screws securing the screen to the 1st stage gear pump. Care should be taken not to remove the center plate and gears. Remove and clean with nonflammable solvent, blow dry clean. Reinstall in reverse order and torque bolts to 75 inch pounds. Keep the motor and pump as clean as possible.

### **Applies to the 5 and 10 gallon reservoirs:**

Unscrew screen from bottom of pump unit and clean with nonflammable solvent. Blow dry and reassemble. Keep areas around pump unobstructed to provide good air flow around the motor and pump. Keep the motor and pump as clean as possible.

## **6.3 FLUSH THE PUMP**

If you suspect your pump has been contaminated or discover sludge or other deposits on internal components, you should thoroughly flush the pump. Remove the old oil from the reservoir, then thoroughly clean the reservoir and refill with a clean, nonflammable flushing oil. Reassemble the pump and motor to the reservoir.

Run the pump in no load condition for 1 or 2 minutes maximum. Unplug the pump and remove the motor and pump assembly again. Now drain the flushing oil and re-clean the inside of the reservoir. (Make sure flushing fluid is also drained from pump assembly). Refill the reservoir with TorcUP hydraulic oil and reassemble the pump.

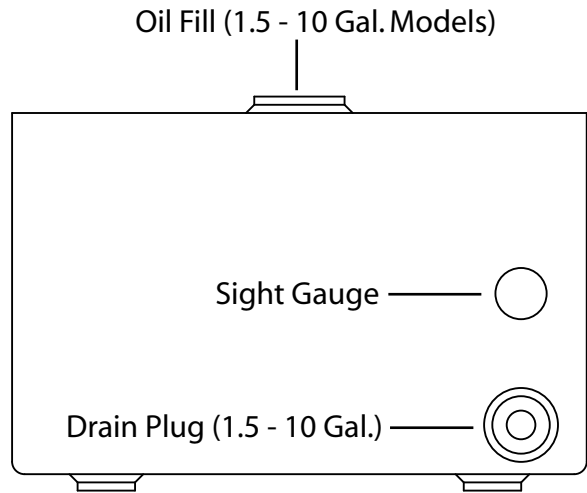

## 7.0 TROUBLESHOOTING

### PROBLEM

### CAUSE-SOLUTION

**Sporadic Tool Action:**

- Air in the hydraulic system. Bleed the hydraulic circuit.
- Check reservoir oil level.

**Motor Will Not Start:**

- Be sure power cord is not damaged.
- Check for tripped circuit breaker; be sure breaker is of adequate size.
- Have motor checked for proper operation.
- Have qualified electrician inspect for loose or faulty wiring or switch.

**Noisy Operation:**

- Air in system.
- Be sure the oil reservoir is filled to normal level.
- Check all points where air might leak into system.
- Clogged or blocked intake screen.

**Pump Oil is Over Heating:**

- Inspect for high pressure leakage at the pump (leaking at plug or relief valve).
- Oil level is low. Fill reservoir to normal level, or retrofit the pump with larger reservoir or heat exchanger.

**Pump Runs But Will Not Pump Oil:**

- Pump is not primed. Run pump a few minutes tipping from side to side.
- Inspect to make sure that external adjustable relief valve is set properly.
- Defective control valve, take to nearest TorcUP Authorized Service Center for repair.
- Incorrect motor rotation, take to nearest TorcUP Authorized Service Center for repair.
- Check to make sure the intake screen is not clogged. Clean if needed.
- Check oil reservoir is low. Fill as needed.
- Oil viscosity is too high. Replace with TorcUP oil.

---

## 1.0 CHEMICAL PRODUCT AND COMPANY IDENTIFICATION

PRODUCT NAME: RYKON® OIL MV

MANUFACTURER/SUPPLIER:  
Amoco Oil Company  
200 East Randolph Drive  
Chicago, IL 60601

EMERGENCY HEALTH INFORMATION:  
1 (800) 447-8735

EMERGENCY SPILL INFORMATION:  
1 (800) 424-9300 CHEMTREC (USA)

OTHER PRODUCT SAFETY INFORMATION:  
(312) 856-3907

---

## 2.0 COMPOSITION/INFORMATION ON INGREDIENTS

COMPONENT	CAS#	RANGE % BY WEIGHT
Solvent refined heavy paraffinic distillate	64741-88-4	80-100

(See section 8.0 "Exposure Controls/Personal Protection" for exposure guidelines)

---

## 3.0 HAZARDS IDENTIFICATION

**EMERGENCY OVERVIEW:** This product has been evaluated and does not require any hazard warning on the label under OSHA criteria.

### POTENTIAL HEALTH EFFECTS:

**EYE CONTACT:** No significant health hazards identified.

**SKIN CONTACT:** Prolonged or repeated contact may produce some skin irritation. High-pressure equipment can inject this product through the skin and cause severe damage.

**INHALATION:** No significant health hazards identified.

**INGESTION:** No significant health hazards identified.

**HMIS CODE:** (Health:0) (Flammability:1) (Reactivity:0)

**NFPA CODE:** (Health:0) (Flammability:1) (Reactivity:0)

---

## 4.0 FIRST AID MEASURES

**EYE:** Flush eyes with plenty of water.

**SKIN:** Wash exposed skin with soap and water. Get medical attention if irritation develops. Get immediate medical attention following injection injuries.

**INHALATION:** If adverse effects occur, remove to uncontaminated area. Get medical attention.

**INGESTION:**

---

## 5.0 FIRE FIGHTING MEASURES

**FLASHPOINT:** 383°F (195°C) (Cleveland open cup)

**UEL:** Not Determined

**LEL:** Not Determined

**AUTOIGNITION TEMPERATURE:** Not Determined

**FLAMMABILITY CLASSIFICATION:** Not Flammable.

**EXTINGUISHING MEDIA:** Agents approved for Class B hazards (e.g. dry chemical, carbon dioxide, foam, steam) or water fog.

**UNUSUAL FIRE AND EXPLOSION HAZARDS:** None Identified.

**FIRE-FIGHTING EQUIPMENT:** Firefighters should wear full bunker gear, including a positive pressure self-contained breathing apparatus.

**HAZARDOUS COMBUSTION PRODUCTS:** Incomplete burning can produce carbon monoxide and/or carbon dioxide and other harmful products.

---

## 6.0 ACCIDENTAL RELEASE MEASURES

Prevent spreading by diking, ditching, or absorbing on inert materials. Keep out of sewers and waterways.

---

## 7.0 HANDLING AND STORAGE

**HANDLING:** No Special Requirements

**STORAGE:** No Special Requirements

---

## 8.0 EXPOSURE CONTROLS/PERSONAL PROTECTION

**EYE:** None required, however, use of eye protection is good industrial practice.

**SKIN:** Wear protective gloves if prolonged or repeated contact is expected.

**INHALATION:** None required, however, use of adequate ventilation is good industrial practice

**ENGINEERING CONTROLS:** Control airborne concentrations below the exposure guidelines

### EXPOSURE GUIDELINES:

COMPONENT	CAS#	EXPOSURE LIMITS
Solvent refined heavy paraffinic distillate	64741-88-4	OSHA PEL: 5mg/m <sup>3</sup> (oil mist) (1989) (1971) ACGIH TLV-TWA: 5 mg/m <sup>3</sup> (oil mist) ACGIH TLV-STEL: 10 mg/m <sup>3</sup> (oil mist)

## 9.0 CHEMICAL AND PHYSICAL PROPERTIES

<b>APPEARANCE AND ODOR:</b>	Oily liquid. Pale yellow
<b>pH:</b>	Not Determined
<b>VAPOR PRESSURE:</b>	Not Determined
<b>VAPOR DENSITY:</b>	Not Determined
<b>BOILING POINT:</b>	Not Determined
<b>MELTING POINT:</b>	Not Determined
<b>SOLUBILITY IN WATER:</b>	Negligible, below 0.1%
<b>SPECIFIC GRAVITY (WATER = 1)</b>	0.87
<b>VISCOSITY:</b>	32.4 – 39.66cSt at 40°C
<b>POUR POINT:</b>	-40oF (-40oC) (maximum)
<b>VISCOSITY INDEX:</b>	95 Minimum

---

## 10.0 STABILITY AND REACTIVITY

**STABILITY:** Stable

**CONDITIONS TO AVOID:** None identified

**MATERIALS TO AVOID:** Avoid chlorine, fluorine, and other strong oxidizers

**HAZARDOUS DECOMPOSITION:** None identified

**HAZARDOUS POLYMERIZATION:** Will not occur.

---

## 11.0 TOXICOLOGICAL INFORMATION

### ACUTE TOXICITY DATA:

**EYE IRRITATION:** Testing not conducted. See other toxicity data.

**SKIN IRRITATION:** Testing not conducted. See other toxicity data

**DERMAL LD50:** Testing not conducted. See other toxicity data

**ORAL LD50:** Testing not conducted. See other toxicity data

**INHALATION LC50:** Testing not conducted. See other toxicity data

### OTHER TOXICITY DATA:

Specific toxicity test have not been conducted on this product. Our hazard evaluation is based on information from similar products, the ingredients, technical literature, and/or professional experience.

No component of this product present at levels greater than 0.1% is identified as a carcinogen by the US National Toxicology Program, the US Occupational Safety and Health Act, or the International Agency on Research on Cancer (IARC).

---

## 12.0 ECOLOGICAL INFORMATION

Ecological testing has not been conducted on this product.

### 13.0 DISPOSAL INFORMATION

Disposal must be in accordance with applicable federal, state, or local regulations. Enclosed – controlled incineration is recommended unless directed otherwise by applicable ordinances. This material may be amenable to recycling.

Since the emptied containers retain product residue, follow label warnings even after container is emptied.

---

### 14.0 TRANSPORTATION INFORMATION

#### US DEPT OF TRANSPORTATION

**Shipping Name: Not Regulated**

#### INTERNATIONAL INFORMATION

##### Sea (IMO/IMDG)

**Shipping Name: Not Determined**

##### Air (ICA/IATA)

**Shipping Name: Not Determined**

##### European Road/Rail (ADR/RID)

**Shipping Name: Not Determined**

##### Canadian Transportation of Dangerous Goods

**Shipping Name: Not Determined**

---

### 15.0 REGULATORY INFORMATION

CERCLA SECTIONS 102A/103 HAZARDOUS SUBSTANCES (40 CFR PART 302.4): This product is not reportable under 40 CFR Part 302.4

SARA TITLE III SECTION 302 EXTREMELY HAZARDOUS SUBSTANCES (40 CFR PART 355): This product is not regulated under Section 302 of SARA and 40 CFR Part 355

SARA TITLE III SECTIONS 311/312 HAZARDOUS CATEGORIZATION (40 CFR PART 370): This product is not regulated under SARA Title III Section 311/312

SARA TITLE III SECTION 313 (40 CFR PART 372): This product is not regulated under Section 313 of SARA and 40 CFR Part 372

US INVENTORY (TSCA): Listed on inventory

This product contains n-methyl pyrrolidone (CAS 872-50-4) which is currently undergoing review and testing under TSCA Section 4. Notification to the US EPA Office of Toxic Substances is required prior to export of this material from the United States.

OSHA HAZARD COMMUNICATION STANDARD: Contains a component listed by OSHA. Contains a component listed by ACGIH

EC INVENTORY (EINECS/ELINCS): Not Determined

JAPAN INVENTORY (MITI): Not Determined

AUSTRALIA INVENTORY (AICS): Not Determined

KOREA INVENTORY (DSL): Not Determined

CANADA INVENTORY (DSL): Not Determined

PHILIPPINE INVENTORY (PICCS): Not Determined

FOOD CONTACT STATUS:

USDA: H2 Status. This product is acceptable to the USDA for use as a lubricant in official meat and poultry establishments provided there is no possibility of the lubricant or lubricated part contacting edible products.

## 16.0 OTHER INFORMATION

Prepared by

Environmental Health and Safety Department

Issued: September 20, 1993

This Material Safety Data Sheet conforms to the requirements of ANSI z400.1

This material safety data sheet and the information it contains are offered to you in good faith as accurate. We have reviewed any information contained in this data sheet, which we received from sources outside our company. We believe the information to be correct, but cannot guarantee its accuracy or completeness. Health and safety precautions in this data sheet may not be adequate for all individuals and/or situations. It is the user's obligation to evaluate and use this product safely and to comply with all applicable laws and regulations. No statement made in this data sheet shall be construed as a permission or recommendation for the use of any product in a manner that might infringe existing patents. Not warranty is made, either express or implied.





21st Century Bolting Tool Technology  
1025 Conroy Place, Easton,  
PA, 18040 U.S.A.  
Phone: 610-250-5800  
sales@torcup.com\* www.torcup.com

## EP500 SERIES TORQUE POWER PUMP

### PARTS IDENTIFICATION MANUAL

Rev. - A  
Date - 10/08

*This illustration is for reference purposes only. The appearance of your unit may differ from the unit shown.*

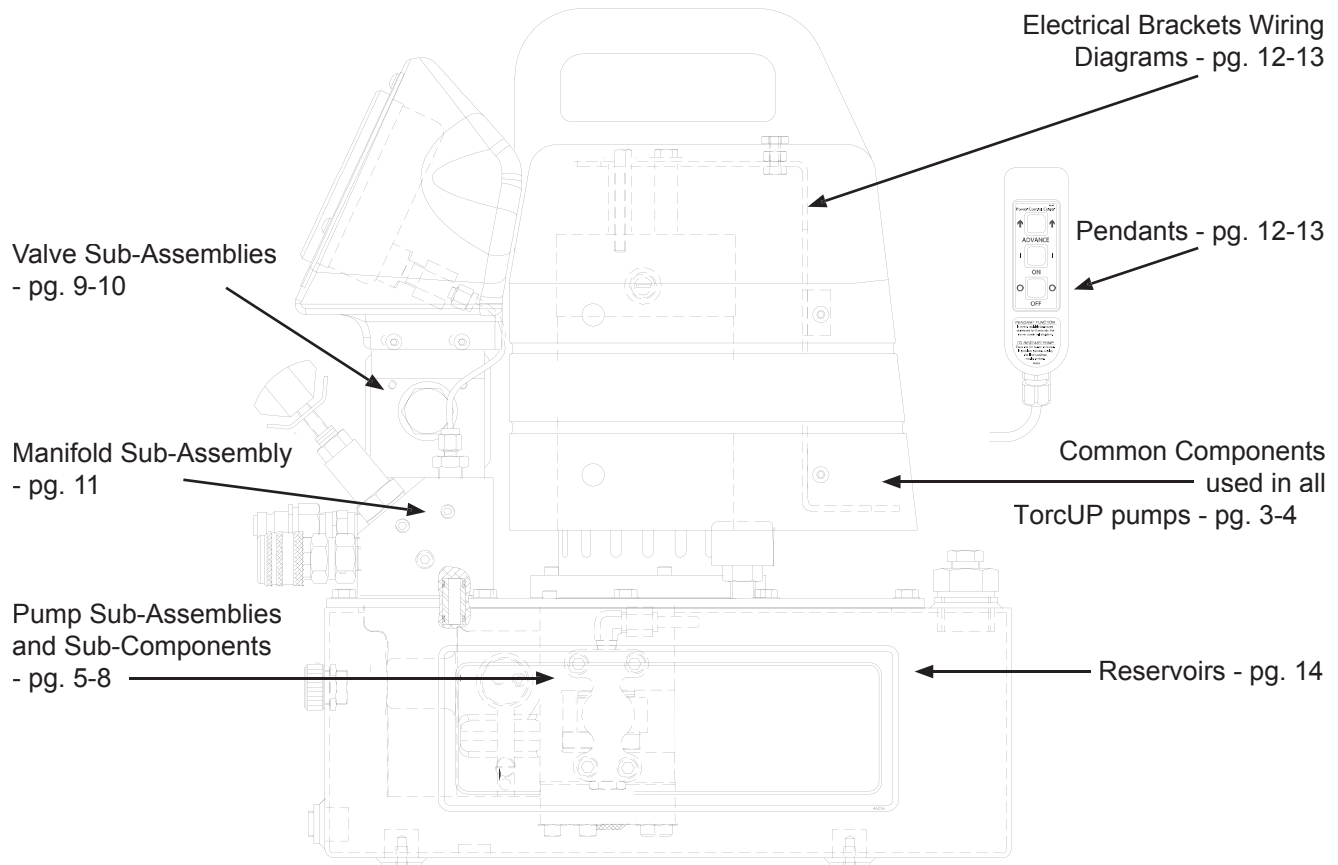

# EP500 Torque Wrench Power Pump

# How to Identify Parts for Your Model.

## MODEL NUMBER & DATE CODE LOCATION

For Example, the date code and serial number

J= **October**

07 = **Year 2007**

42= **Week number in year**

**J 07 42**

A	B	C	D	E	F	G	H	I	<b>J</b>	K	L
1	2	3	4	5	6	7	8	9	<b>10</b>	11	12

DATE CODE COVER PLATE  
STAMPING LOCATION

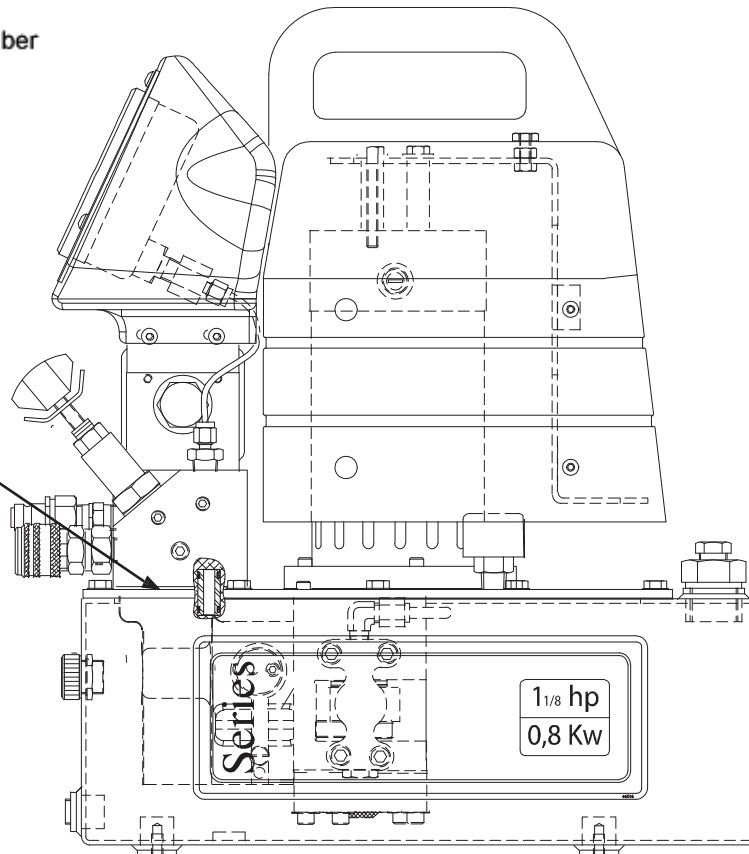

MODEL DECAL  
PLACEMENT

# EP500 Torque Wrench Power Pump

# Common components used in pumps

NOTE: This illustration is for reference only. The appearance of your unit may differ from unit shown.

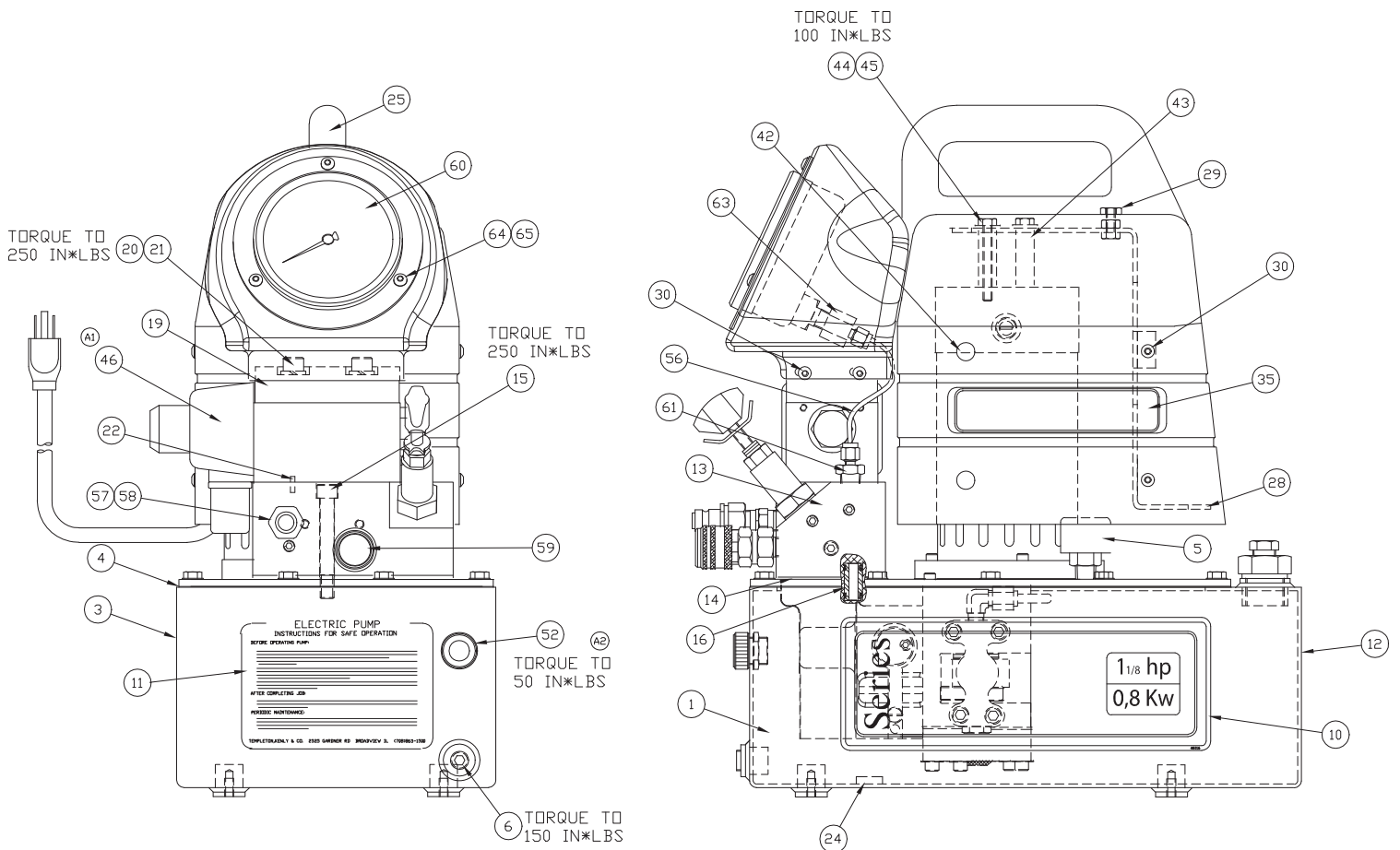
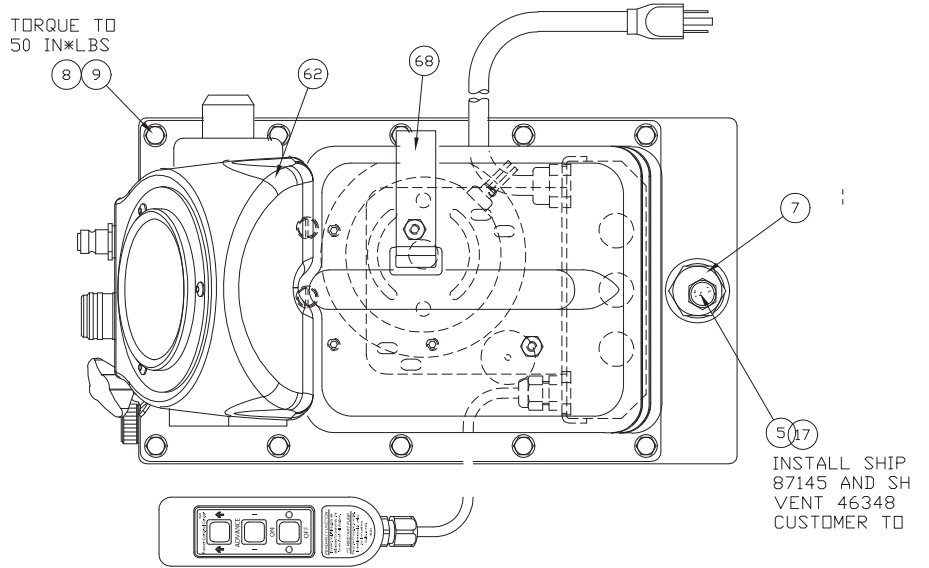

# EP500 Torque Wrench Power Pump

# Common components used in pumps

Continued...

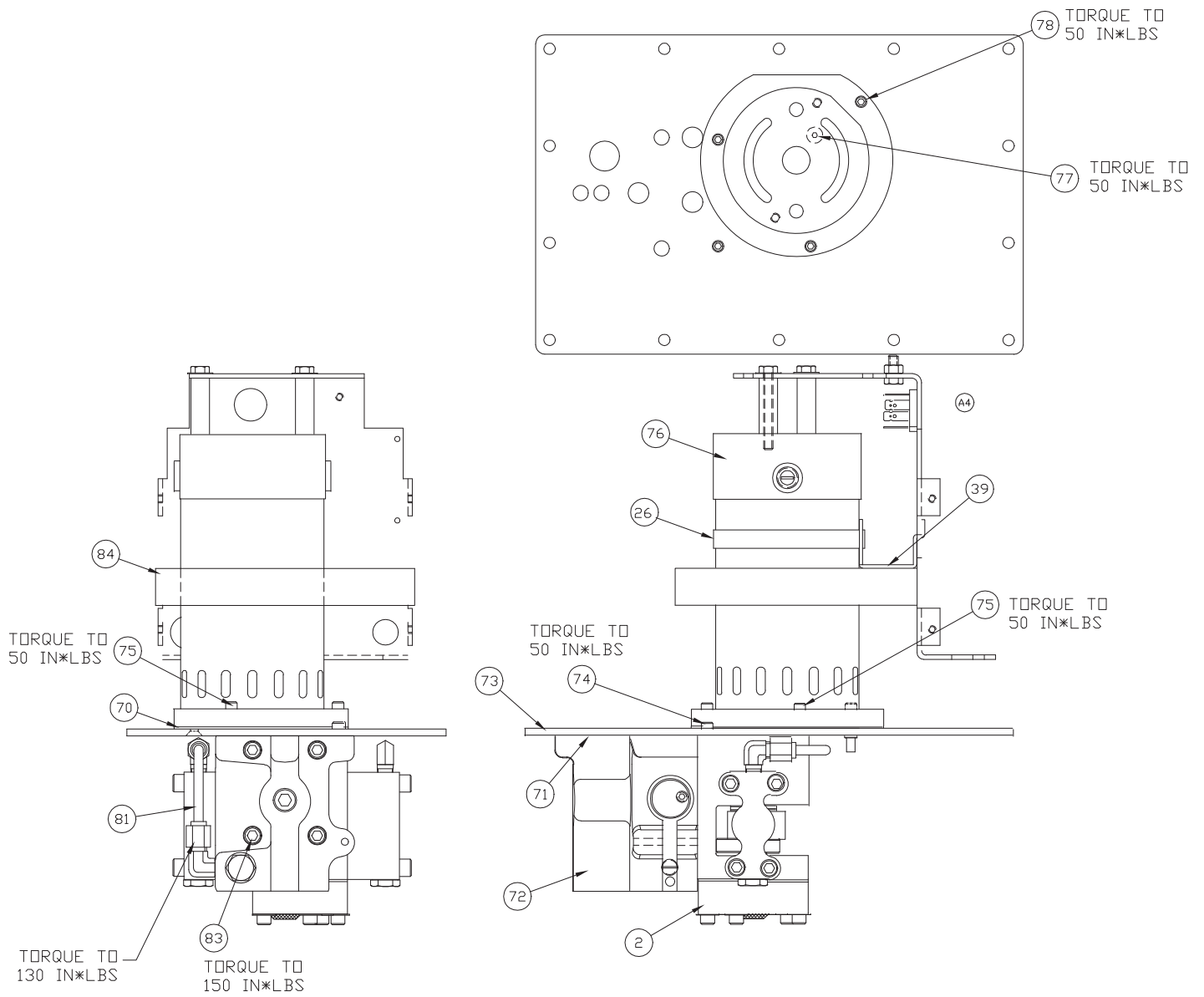

# EP500 Torque Wrench Power Pump

# Common components used in pumps

ITEM #	DESCRIPTION	115 V.	230 V.	QTY.
02	PUMP ASSEMBLY	SEE PAGE 6-10		1.00
03	RESERVOIR BLACK	SEE PAGE 15		1.00
04	RESERVOIR GASKET	*		1.00
05	BREATHER VENT 3/8" NPT	46348	46348	1.00
06	PIPE PLUG 1/4" W/ COATING	46510	46510	1.00
07	SAE #12 HEX PLUG WITH PORT	46118	46118	1.00
08	HHCS 1/4-20 X .75 PLT	65891	65891	14.00
09	SEALING WASHER	65892	65892	14.00
10	G3 RESERVOIR DECAL	46016	46016	2.00
11	LABEL SAFE USE ELEC	68068	68068	1.00
12	BLANK DECAL 3 X 4	87305	87305	1.00
13	MANIFOLD ASM.	SEE PAGE 12		1.00
14	VALVE GASKET	69242	69242	1.00
15	SHCS 3/8-16 X 2 3/4	99921	99921	3.00
16	ADAPTER ASSY.	68963	68963	1.00
17	HEX PIPE PLUG 3/8" COATING	46513	46513	1.00
19	VALVE ASM. 2P/4W	SEE PAGE 11		1.00
20	SHCS 3/8-16 X 3 1/2	88363	88363	4.00
21	LOCK WASHER 3/8	93943	93943	4.00
22	ROLL PIN 1/8 X 3/8 LG	561604	561604	1.00
24	MAGNET	66021	66021	1.00
25	MOTOR SHROUD W/ HANDLE	45534	45534	1.00
26	HOSE CLAMP	69235	69235	1.00
27	DECAL OVERLAY	46539	46539	1.00
28	BRACKET ASM G PET	SEE PAGE 13-14		1.00
29	HEAVY HEX JAM NUT 1/4-20	69234	69234	2.00

ITEM #	DESCRIPTION	115 V.	230 V.	QTY.
30	BHCS 10-24 x 3/8 LG	69236	69236	4.00
30	BHCS 10-24 x 3/8 LG	69236	69236	4.00
35	SIMPLEX DECAL 5.71" x 1.15"	46355	46355	2.00
39	BRACKET SUPPORT G3	46338	46338	1.00
42	HOLE PLUG 1/4"	46405	46405	4.00
43	SPACER 1.5" LONG	46010	46010	2.00
44	HHCS 1/4-20 X 2.00	40970	40970	2.00
45	WASHER 1/4" SS	88429	88429	2.00
46	COIL WITH DIN CONNECTOR	46294	46324	1.00
52	SIGHT GAUGE	46009	46009	1.00
53	MEMBRAN SWITCH DECAL	++		
54	DECAL PENDANT INSTRUCT.	++		
55	SIMPLEX DECAL 5.71" x 1.15"	++		
57	1/4 IN NIPPLE	4100067	4100067	1.00
58	1/4" NIPPLE	CT210	CT210	1.00
59	1/4" SELF-LOCKING COUPLER	45765	45765	1.00
62	GAUGE SHROUD ASM	46474	46474	1.00
68	VELCRO STRAP 1x14	46310	46310	1.00
70	MOTOR GASKET	*		1.00
71	GASKET POW'R PUMP	*		1.00
73	COVER PLATE	SEE PAGE 15		1.00
74	SHCS #10-24 X 5/8"	86699	86699	1.00
75	SHCS #10-24 X 1" LG	41327	41327	2.00
76	G3 MOTOR 1.5HP 115V	45418	45428	1.00
77	FHCS 10-24 X 0.50LG	43557	43557	1.00
78	SHCS #10-32 X .875	45084	45084	1.00
84	FOAM INSERT	46352	46352	1.00

NOTES : PENDANT DECAL KIT (+ + = COMPONENTS) -- PART # 54489  
REBUILD KIT (\* = COMPONENTS) -- PART # 54487

# EP500 Torque Wrench Power Pump

# Pump Assembly

## (46541) PUMP ASM.

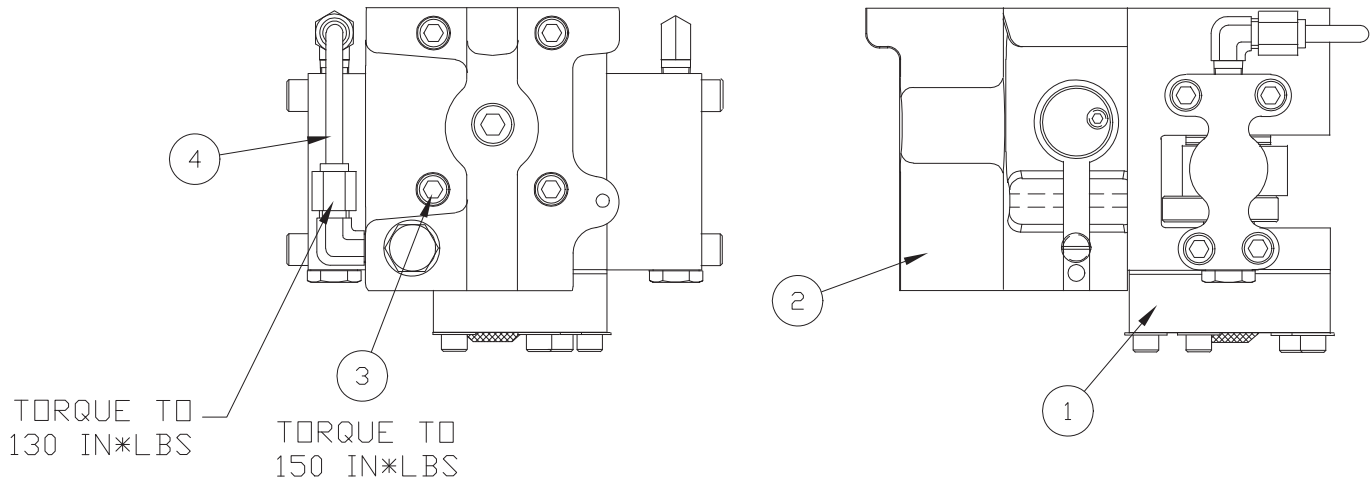

ITEM #	DESCRIPTION	PART #	QTY.
01	GEAR SECTION ASSEMBLY	SEE PAGE 7-8	1.00
02	PUMP VALVE SECTION ASSEMBLY	SEE PAGE 9	1.00
03	SHCS 5/16-24 X 1" LG	84188	4.00
04	PISTON BLOCK TUBE G3	45537	1.00

# EP500 Torque Wrench Power Pump

# Gear Section Assembly

## (45535) GEAR SECTION ASM.

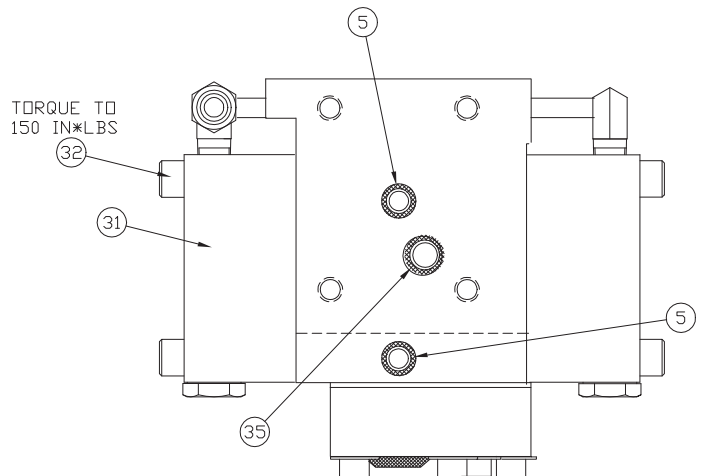
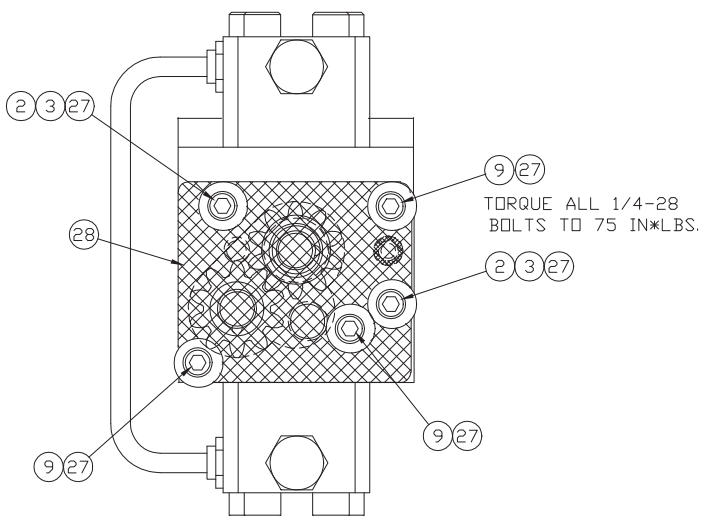
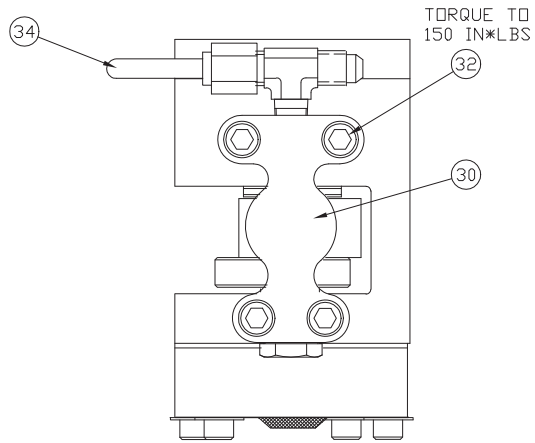
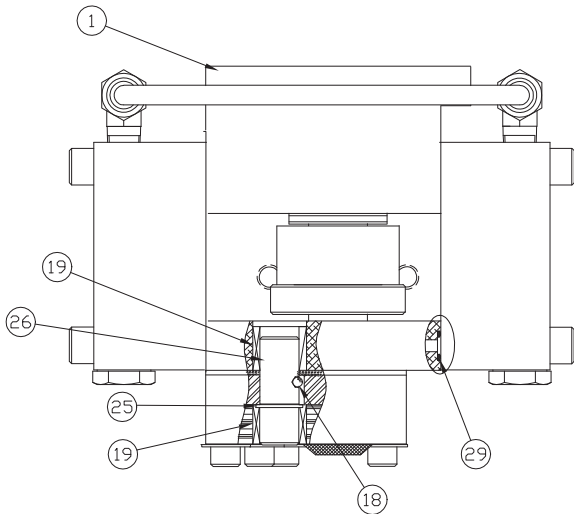
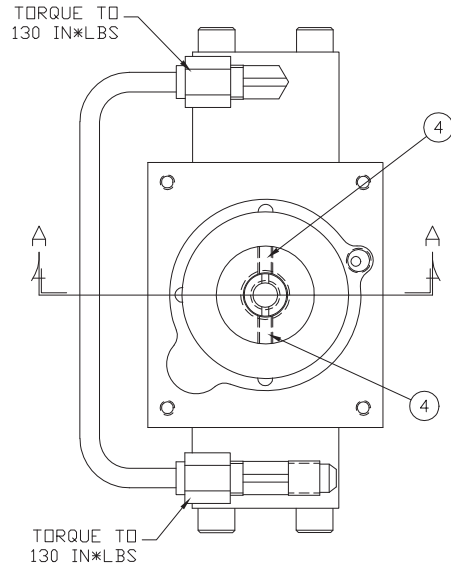
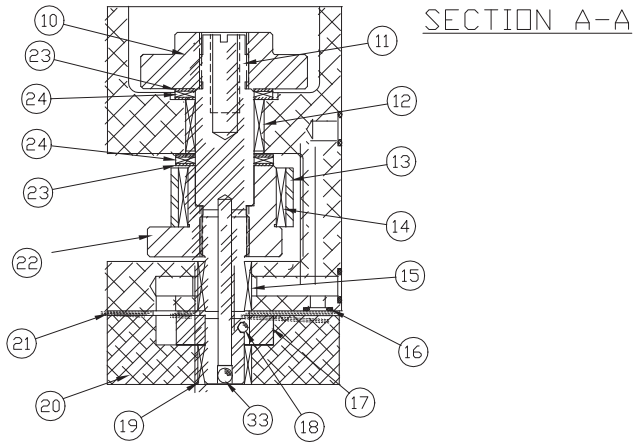

# EP500 Torque Wrench Power Pump

# Gear Section Assembly

## (45535) GEAR SECTION ASM.

ITEM #	DESCRIPTION	PART #	QTY.
01	G3 PUMP BODY 2 PISTON	45419	1.00
02	TUBE-GUIDE .11	68894	2.00
03	SHCS 1/4-28 X 1 1/2	89148	2.00
04	SET SCREW #10-24 X 1/4 CUP	44596	2.00
05	O-RING 5/16X7/16	*	2.00
09	SHCS 1/4-28 X 1.25LG	40118	3.00
10	POW'R BUD REDUC GEAR	43520	1.00
11	POW'R BUDDY PUMP SHAFT	43278	1.00
12	ROLL BRG 3/4ID X 5/8	43346	1.00
13	POW'R BUD ECC RING	43353	1.00
14	ROLL BRG 1 1/8 X 3/4	43347	1.00
15	BEARING ROLLER 1/2x11/16x1/2 WIDE	68891	1.00
16	O RING 1/4X3/8	*	1.00
17	GEAR-PUMP .375	68896	2.00
18	BALL 1/8"	90906	2.00
19	BEARING ROLLER 1/2x11/16x1/2 WIDE	69330	3.00
20	BOTTOM PLATE 3/8" GEARS G3	45536	1.00
21	POW'R BUDDY WEAR PLATE	43279	1.00
22	POW'R BUDDY ECCENTRIC RING	43275	1.00
23	THRUST WASHER 3/4"ID	43349	4.00
24	THRUST BRG 3/4" ID	43348	2.00
25	POW'R BUDDY IDLER SHAFT	43276	1.00
26	RING-RETAINING	68892	1.00
27	WASHER 1/4" SS	88429	5.00
28	POW'R BUDDY SCREEN	*	1.00
29	O-RING 3/16X5/16	*	2.00
30	PISTON BLOCK ASSEMBLY #1 G3	SEE PAGE 10	1.00
31	PISTON BLOCK ASSEMBLY G3	SEE PAGE 10	1.00
32	SHCS 5/16-24 X 1.75	69392	8.00
33	BALL 3/16"	90548	1.00
34	G3 PISTON BLOCK TUBE	45420	1.00
35	O-RING 3/8X1/2	*	1.00

REBUILD KIT (\* = COMPONENTS) -- PART # 54487



# EP500 Torque Wrench Power Pump

# Sub Component Assemblies

## (45533) PISTON BLK ASM.

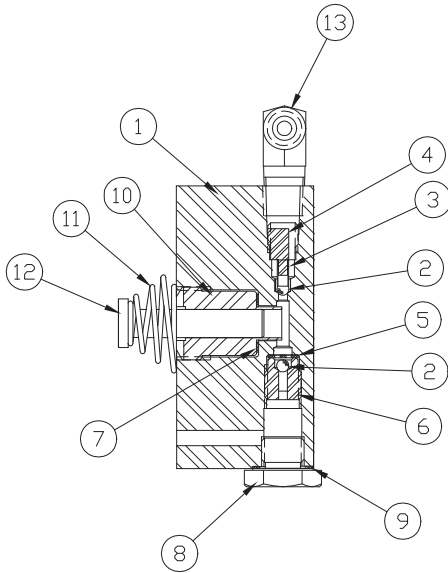

ITEM #	DESCRIPTION	PART #	QTY.
01	GEN II PISTON BLOCK	45539	1.00
02	BALL 1/8"	90906	2.00
03	SPRING	66042	1.00
04	BALL STOP	68810	1.00
05	BALL RETAINER	66043	1.00
06	INTAKE SEAT	66046	1.00
07	GASKET 29/64 X 5/8	*	1.00
08	PLUG PISTON BLOCK	68825	1.00
09	GASKET 25/64X19/32	*	1.00
10	ADAPTER-.290 PISTON	68820	1.00
11	SPRING, PISTON	68340	1.00
12	PISTON-.290 DIA	68819	1.00
13	MALE TEE 1/8" PIPE 1/4" TUBE	45426	1.00

## (45538) PISTON BLK ASM.

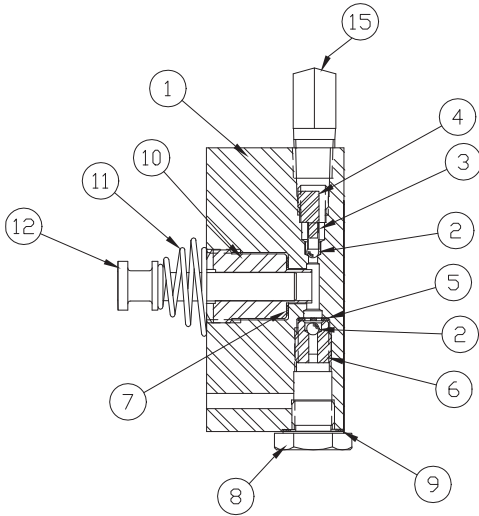

ITEM #	DESCRIPTION	PART #	QTY.
01	PISTON BLOCK	45539	1.00
02	BALL 1/8"	90906	2.00
03	SPRING	66042	1.00
04	BALL STOP	68810	1.00
05	BALL RETAINER	66043	1.00
06	INTAKE SEAT	66046	1.00
07	GASKET 29/64 X 5/8	*	1.00
08	PLUG PISTON BLOCK	68825	1.00
09	GASKET 25/64X19/32	*	1.00
10	ADAPTER-.290 PISTON	68820	1.00
11	SPRING, PISTON	68340	1.00
12	PISTON 0.290" DIA.	45425	1.00
13	MALE ELBOW 1/8 PIPE	69354	1.00

## (43687) UNLOADING PISTON ASM.

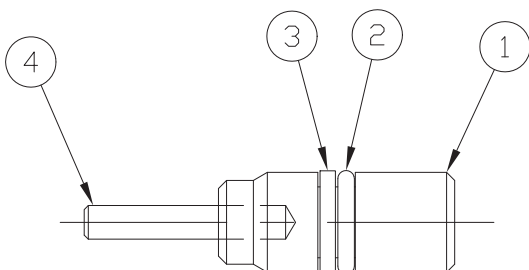

ITEM #	DESCRIPTION	PART #	QTY.
01	UNLOAD PISTON	68209	1.00
02	O RING 1/4X3/8	*	1.00
03	BACK-UP WASHER	68145	1.00
04	DOWEL PIN 1/8X3/4 LG	43686	1.00

REBUILD KIT ( \*= COMPONENTS) -- PART # 54487

# EP500 Torque Wrench Power Pump

# Pump Valve Section Assembly

(46025) PUMP VALVE SECT ASM.

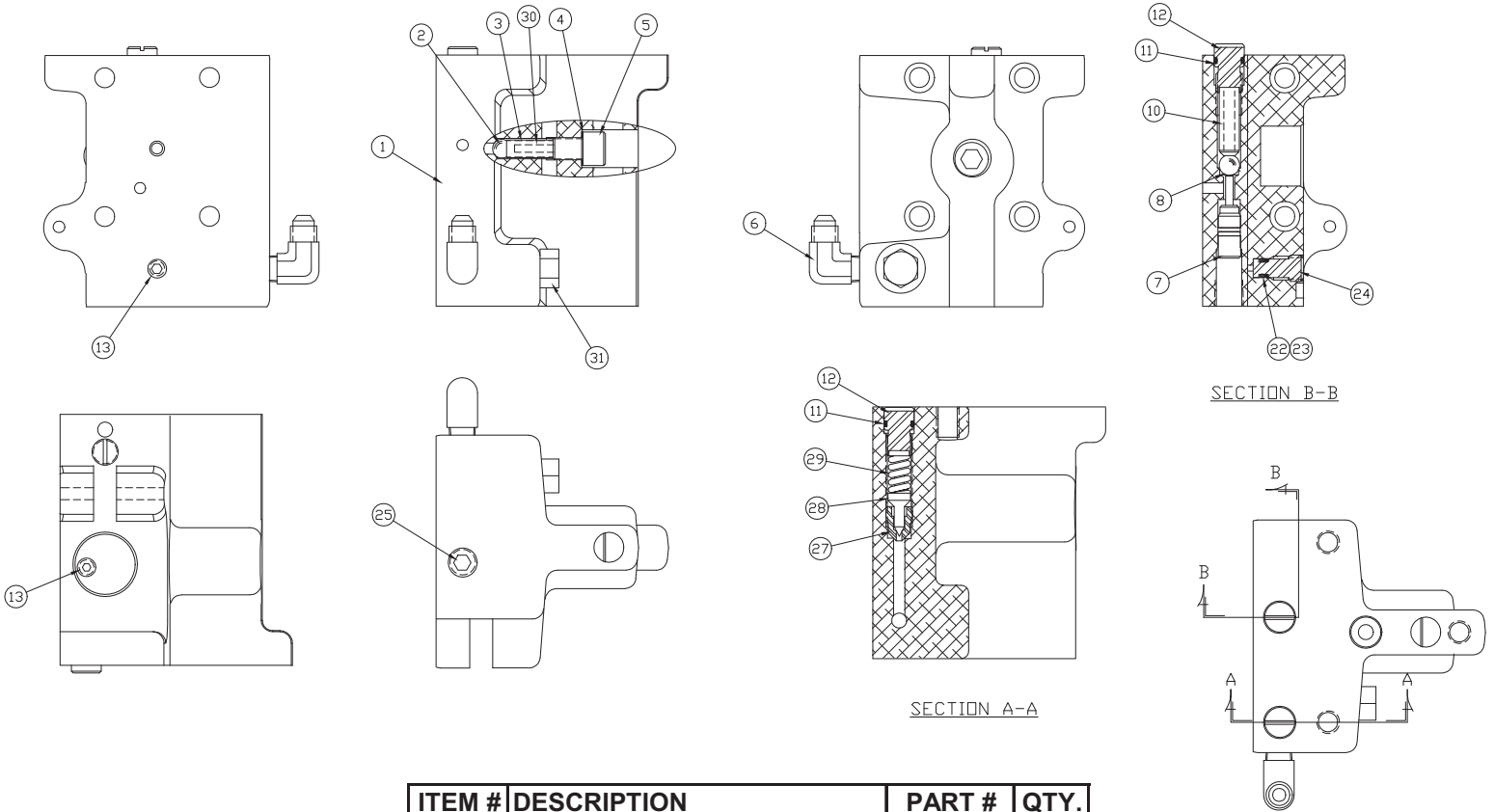

ITEM #	DESCRIPTION	PART #	QTY.
01	PB VALVE BODY SECT.	43269	1.00
02	BALL 5/16"	91701	1.00
03	SPRING	68225	1.00
04	GASKET 25/64X19/32	*	1.00
05	SCREW, BALL STOP	68226	1.00
06	MALE ELBOW 1/8 PIPE	69354	1.00
07	UNLOADING PISTON ASM	PAGE 9	1.00
08	BALL 11/32"	94219	1.00
10	SPRING UNLOADING VLV	68981	1.00
11	O-RING 3/8X1/2	*	2.00
12	ADJUSTING SCREW	43274	2.00
13	1/16 SOC PIPE PLUG	97641	2.00
22	O-RING 3/16X5/16	*	1.00
23	BACKUP WASHER	56080087	1.00
24	POW'R BUD DUMP PLUG	43283	1.00
25	1/4 SOC PIPE PLUG	93950	1.00
27	SEAT - EXT RELIEF	++	1.00
28	CONE - EXT RELIEF	++	1.00
29	SPRING - RELIEF VALVE	++	1.00
30	ROLL PIN 1/8X15/16	81332	1.00
31	PLUG SAE #4	68258	1.00

REBUILD KIT (\* = COMPONENTS) -- PART # 54487

RELEIF REPLACEMENT KIT ( ++ = COMPONENTS) -- PART #55057

# EP500 Torque Wrench Valve Sub Assemblies Power Pump

(46291) 3 & 4 WAY SOLENOID VALVE 115V. / 230V.

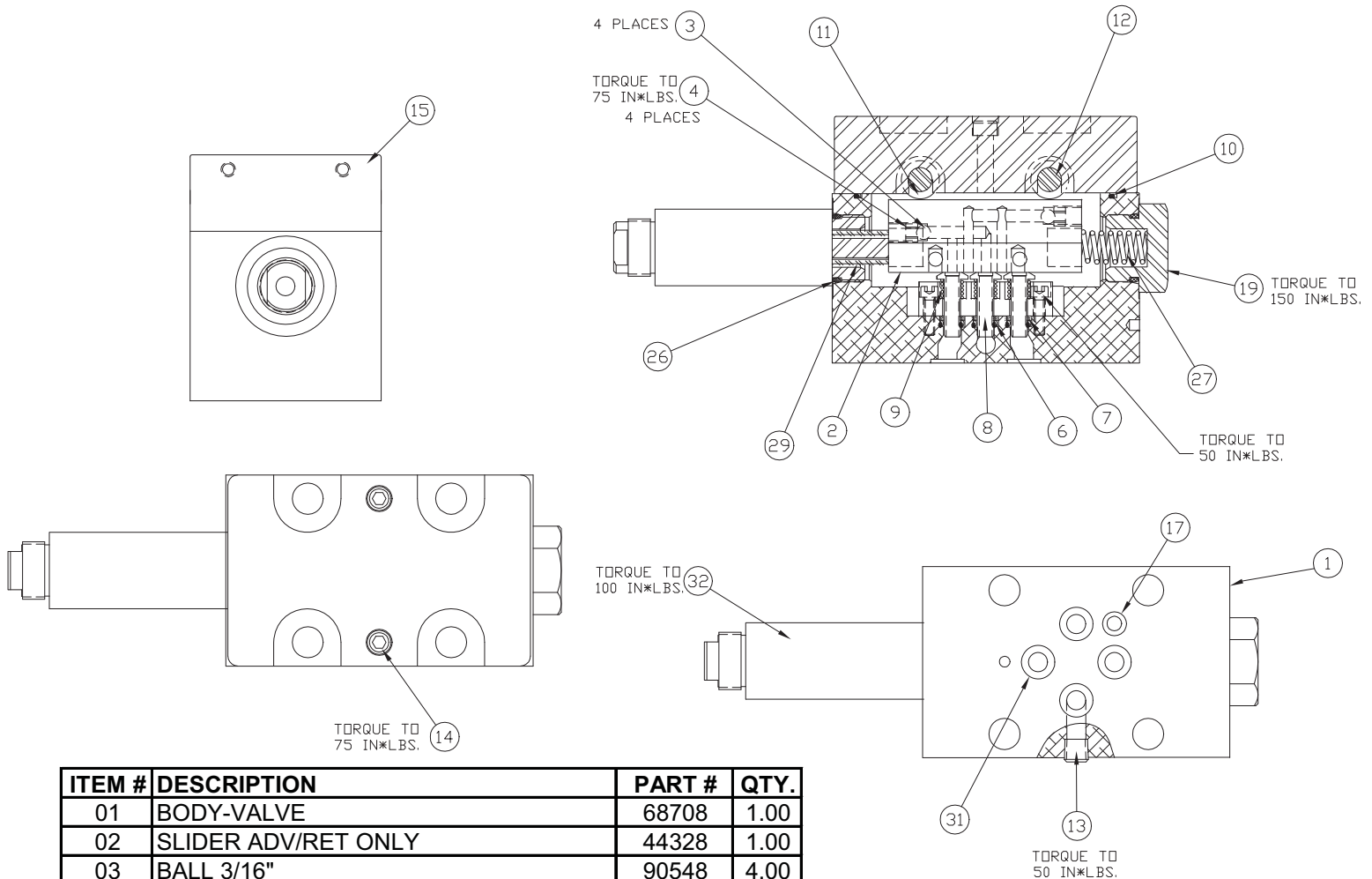

ITEM #	DESCRIPTION	PART #	QTY.
01	BODY-VALVE	68708	1.00
02	SLIDER ADV/RET ONLY	44328	1.00
03	BALL 3/16"	90548	4.00
04	SET SCREW 1/4-28 X 1/4 CUP	40254	4.00
06	O-RING 7/32X11/32	*	3.00
07	BACK UP WASHER	*	3.00
08	SHEAR SEAL	68383	3.00
09	SPRING	68384	3.00
10	O-RING 2 5/8 X 2 3/4	*	1.00
11	BEARING ROLLER 5/16x1/2x5/16 WIDE	68385	4.00
12	PIN BEARING	68390	2.00
13	PIPE PLUG FLUSH 1/16 W/ COATING	40049	1.00
14	SHCS #10-32 X 1" LG PLATED	68264	2.00
15	VALVE TOP PLATE MACHINED	46272	1.00
17	O-RING 3/16X5/16	*	1.00
19	VALVE PLUG 2 POSITION SLIDER	46271	1.00
26	O-RING SAE PORT #10	*	2.00
27	SPRING	68711	1.00
29	SPACER VALVE SLIDER	46418	1.00
31	O-RING 5/16X7/16 URE	*	4.00
32	PUSHER-SOLENOID	68729	1.00

PACKING KIT 3 & 4 WAY SOLENOID VALVE

(\* = COMPONENTS) -- PART #54491

# EP500 Torque Wrench Power Pump

# Manifold Assembly

## (46292) MANIFOLD ASM.

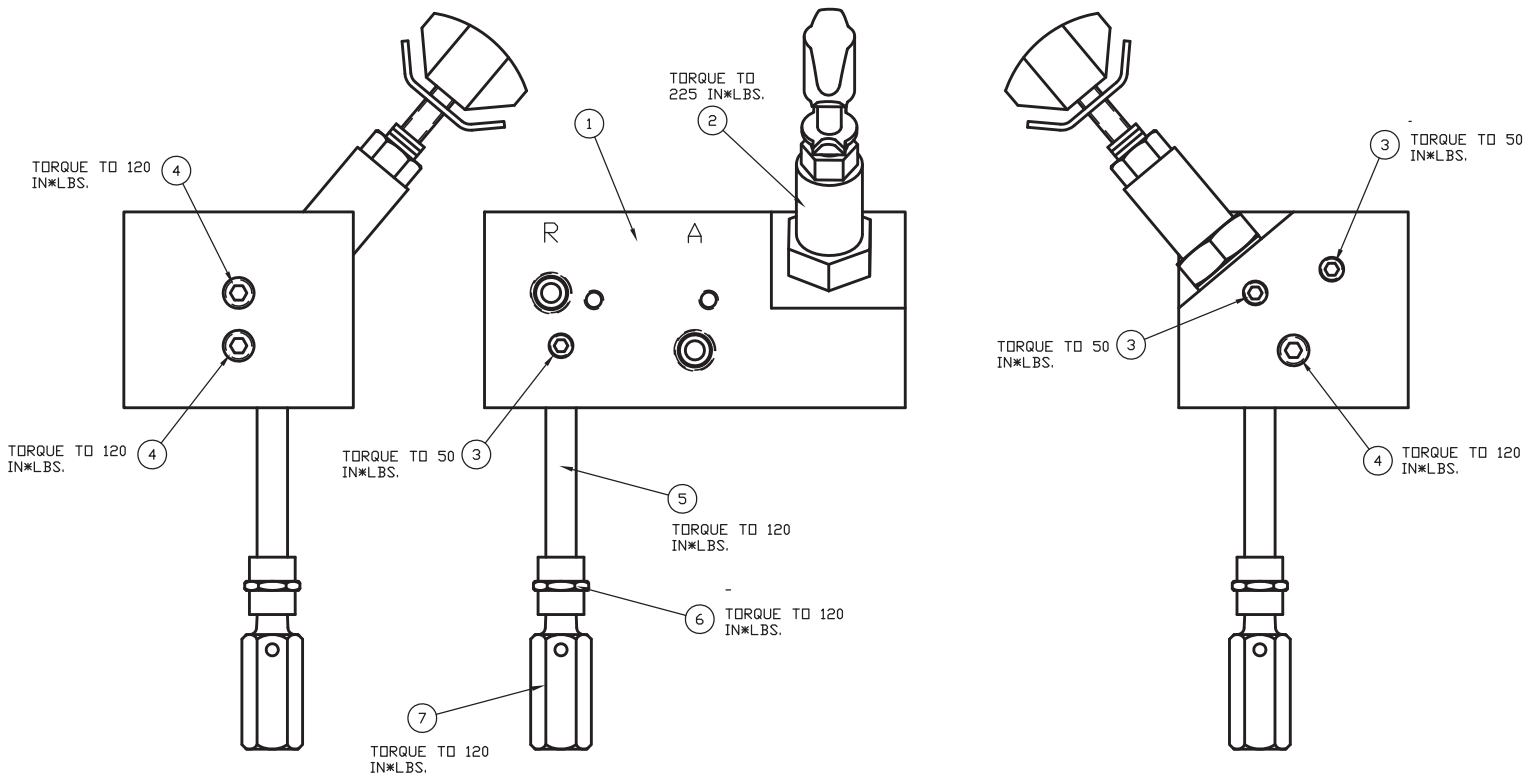

ITEM #	DESCRIPTION	PART #	QTY.
01	VALVE MANIFOLD	46270	1.00
02	CARTRIDGE RELIEF VALVE	45423	1.00
03	1/16 PIPE PLUG-FLUSH	40049	3.00
04	PIPE PLUG 1/8" FLUSH	81093	3.00
05	PIPE NIPPLE 1/8 NPT	68917	1.00
06	PIPE COUPLING 1/8	68918	1.00
07	INT.RELIEF ASM HF	68999	1.00

## (68999) INT. RELIEF ASM.

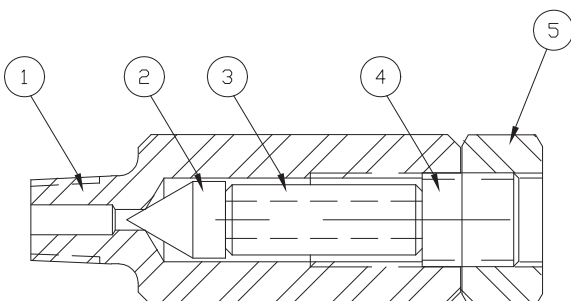

ITEM #	DESCRIPTION	PART #	QTY.
01	CARTRIDGE	66096	1.00
02	CONE REL VLVE	66086	1.00
03	POPPET RELIEF SPRING	44641	1.00
04	RELIEF VALVE ADJUSTING SCREW	66083	1.00
05	HEX NUT 7/16-20	68920	1.00

# EP500 Series Electric Bracket Sub Assemblies Power Pump

## (46483) BRACKET SUB ASM. 115V.

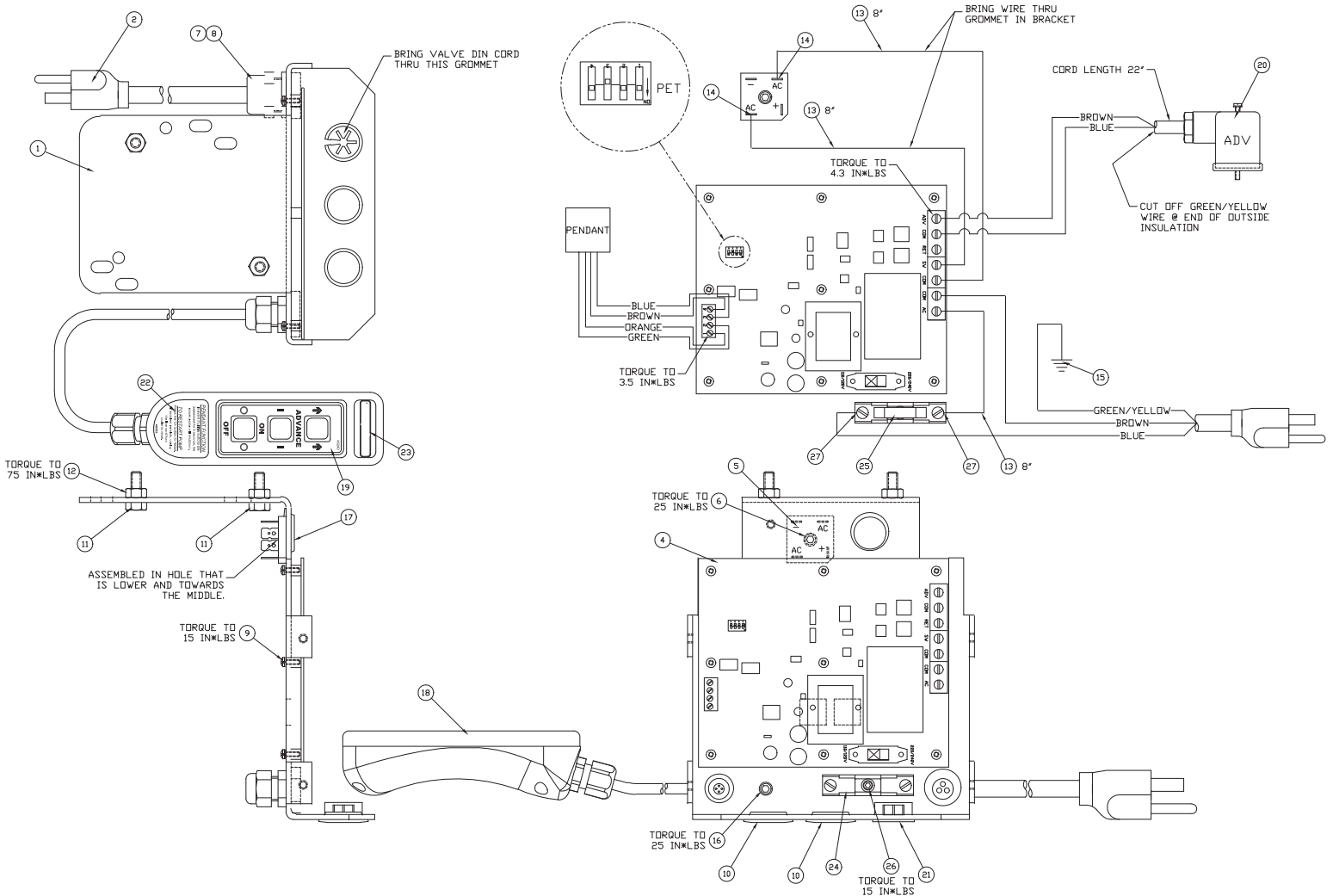

ITEM #	DESCRIPTION	PART #	QTY.
01	MOUNTING BRACKET	46233	1.00
02	PLUG AND CORD ASSY	68595	1.00
04	CIRCUIT BOARD BASIC	46196	1.00
05	BRIDGE RECTIFIER 25A	68623	1.00
06	SHCS #10-32 X 1/2	66805	1.00
07	FITTING,CORD L-TIGHT	68375	1.00
08	LOCKNUT 1/2 INCH	85510	1.00
09	MACHINE SCREW W/ LOCK WASH	46248	5.00
10	HOLE PLUG 7/8"	69652	2.00
11	HHCS 1/4-20 X .75 PLT	65891	2.00
12	HEX NUT 1/4-20 PLATD	93849	2.00
13	WIRE #14 BLACK	68261B	2.00
14	QUICK DISCON. FLAG BLUE	44491	2.00

ITEM #	DESCRIPTION	PART #	QTY.
15	RING TERMINAL 1/4"	69917	1.00
16	SHCS #10-32X1/4" LG PLATED	45175	1.00
17	GROMMET 7/8" HOLE	69855	1.00
18	PENDANT ASSEMBLY BASIC	46220	1.00
19	MEMBRANE SWITCH LABEL PET	*	1.00
20	MOLDED DIN CONNECTOR W/ CORD	46327	1.00
21	PUSH THRU BUSHING	46420	1.00
22	DECAL PENDANT INSTRUCTION	*	1.00
23	SIMPLEX DECAL 1.25" x 0.25"	*	1.00
24	FUSE HOLDER 30 AMP	46481	1.00
25	FUSE 25 AMP	46482	1.00
26	SHCS #6-32 x 1/4 LONG	46506	1.00
27	SPADE TERMINAL	68116	2.00

PENDANT DECAL KIT (\* = COMPONENTS) -- PART # 54489

# EP500 Series Electric Bracket Sub Assemblies Power Pump

**(46484) BRACKET SUB ASM. 230V.**

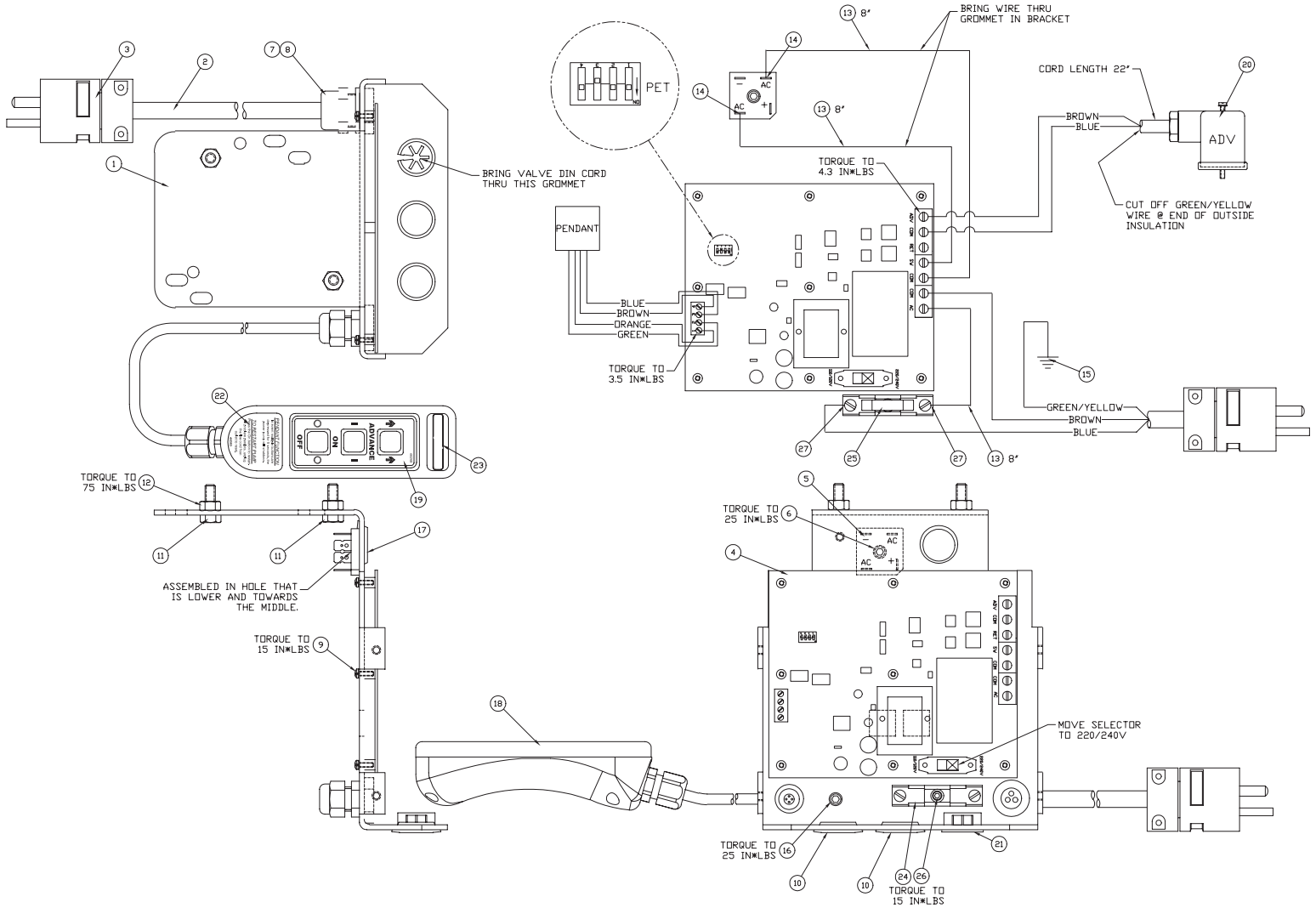

ITEM #	DESCRIPTION	PART #	QTY.
01	MOUNTING BRACKET	46233	1.00
02	POWER CORD 14-3 IEC	69604R	72.00
03	PLUG 20 AMPS-250V	87093	1.00
04	CIRCUIT BOARD BASIC	46196	1.00
05	BRIDGE RECTIFIER 25A	68623	1.00
06	SHCS #10-32 X 1/2	66805	1.00
07	FITTING, CORD L-TIGHT	68375	1.00
08	LOCKNUT 1/2 INCH	85510	1.00
09	MACHINE SCREW W/ LOCK WAS	46248	5.00
10	HOLE PLUG 7/8"	69652	2.00
11	HHCS 1/4-20 X .75 PLT	65891	2.00
12	HEX NUT 1/4-20 PLATD	93849	2.00
13	WIRE #14 BLACK	68261B	2.00
14	QUICK DISCON. FLAG BLUE	44491	2.00

ITEM #	DESCRIPTION	PART #	QTY.
15	RING TERMINAL 1/4"	69917	1.00
16	SHCS #10-32X1/4" LG PLATED	45175	1.00
17	GROMMET 7/8" HOLE	69855	1.00
18	PENDANT ASSEMBLY BASIC	46220	1.00
19	MEMBRANE SWITCH LABEL PET	*	1.00
20	MOLDED DIN CONNECTOR W/ CORD	46327	1.00
21	PUSH THRU BUSHING	46420	1.00
22	DECAL PENDANT INSTRUCTION	*	1.00
23	SIMPLEX DECAL 1.25" x 0.25"	*	1.00
24	FUSE HOLDER 30 AMP	46481	1.00
25	FUSE 25 AMP	46482	1.00
26	SHCS #6-32 x 1/4 LONG	46506	1.00
27	SPADE TERMINAL	68116	2.00

PENDANT DECAL KIT (\* = COMPONENTS) -- PART # 54489

# EP500 Torque Wrench Power Pump

## Reservoirs

**(46109P) 1.0 GALLON RESERVIOR**

**(45996P) 1.5 GALLON RESERVIOR**

**(46213P) 2.5 GALLON RESERVIOR**

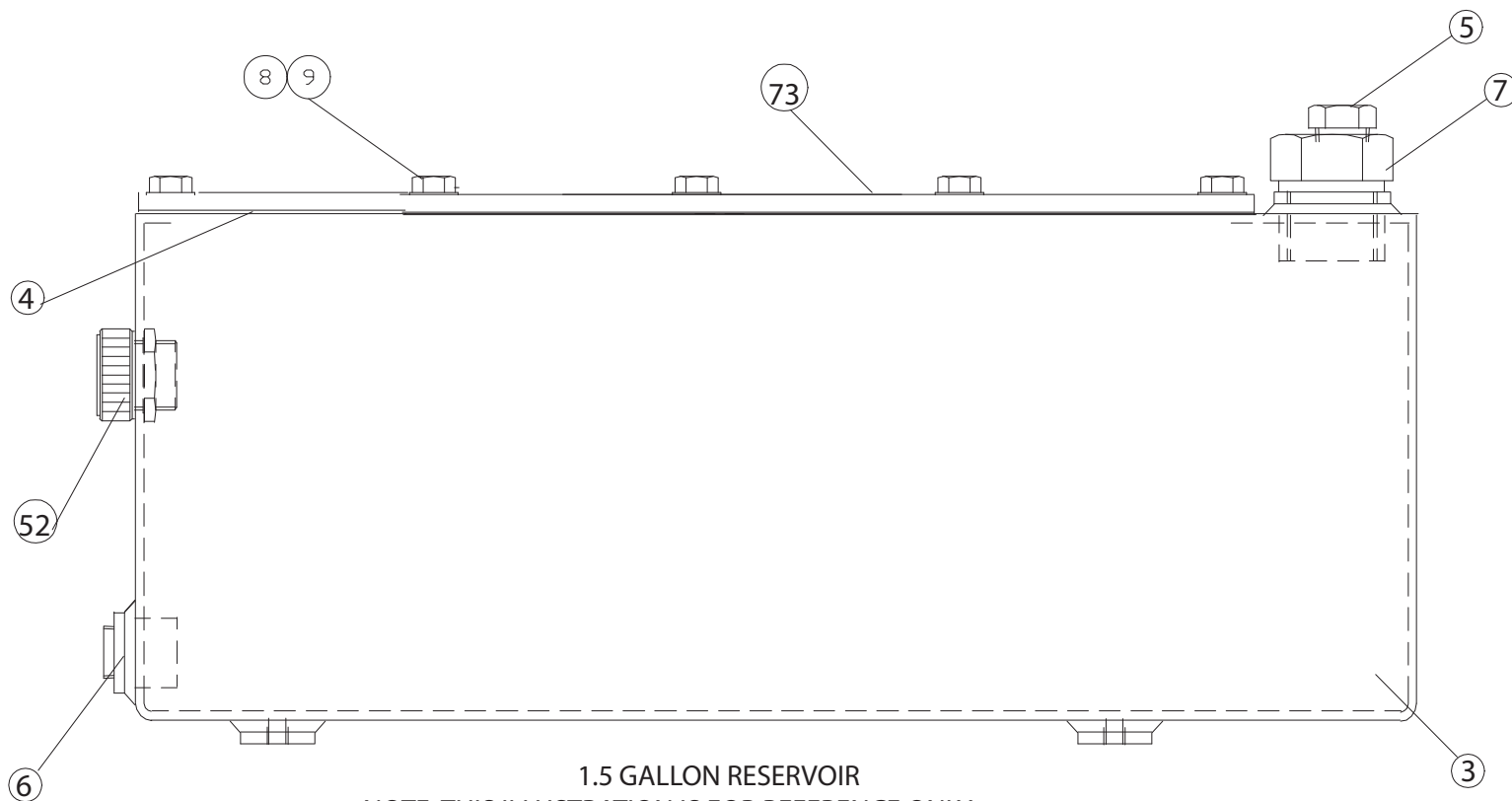

1.5 GALLON RESERVOIR

NOTE: THIS ILLUSTRATION IS FOR REFERENCE ONLY.  
THE APPEARANCE OF YOUR UNIT MAY DIFFER  
FROM UNIT SHOWN.

ITEM #	DESCRIPTION	1.0 GALLON	QTY.	1.5 GALLON	QTY.	2.5 GALLON	QTY.
03	RESERVOIR	46109P	1.00	45996P	1.00	46213P	1.00
04	RESERVOIR GASKET	43565	1.00	85469	1.00	85469	1.00
05	BREATHER VENT 3/8" NPT	68000	1.00	46348	1.00	46348	1.00
06	1/4 SOC PIPE PLUG	93950	1.00	93950	1.00	93950	1.00
07	SAE #12 HEX PLUG WITH PORT	N/A	0.00	46118	1.00	46118	1.00
08	HHCS 1/4-20 x 3/4 LG PLATED	65891	9.00	65891	14.00	65891	14.00
09	SEALING WASHER	65892	9.00	65892	14.00	65892	14.00
52	SIGHT GAUGE	46009	1.00	46009	1.00	46009	1.00
73	COVER PLATE	46350	1.00	45928	1.00	45928	1.00

NOTE: ALL RESERVOIRS ARE POWDER COATED BLACK

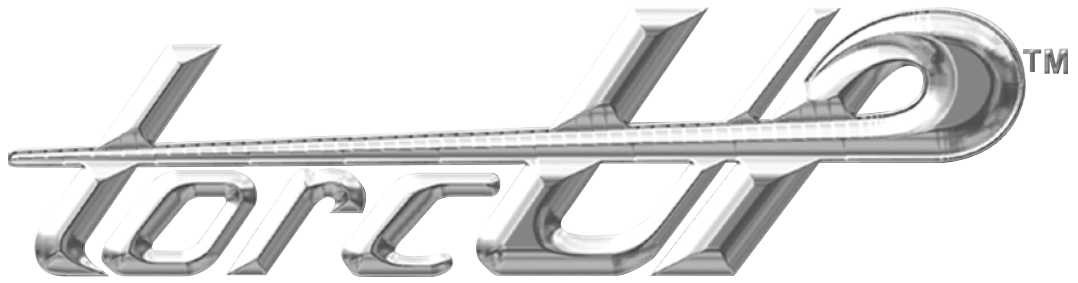

---

**21st Century Bolting Tool Technology**  
**1025 Conroy Place, Easton,**  
**PA, 18040 U.S.A.**  
**Phone: 610-250-5800**  
**sales@torcup.com\* www.torcup.com**

---

TorcUP PRODUCTS ARE WARRANTED TO BE FREE OF DEFECTS IN MATERIALS AND WORKMANSHIP UNDER NORMAL USE FOR AS LONG AS THE ORIGINAL PURCHASER OWNS THEM, SUBJECT TO THE GUIDELINES AND LIMITATIONS LISTED. THIS WARRANTY DOES NOT COVER : NORMAL WEAR AND TEAR, COSMETIC ITEMS, ABUSE, OVERLOADING, ALTERATIONS. IMPROPER FLUID, OR USE IN A MANNER FOR WHICH THEY ARE NOT INTENDED. IF THE CUSTOMER BELIEVES A PRODUCT IS DEFECTIVE, THE PRODUCT MUST BE DELIVERED, OR SHIPPED FREIGHT PREPAID, TO THE NEAREST TorcUP AUTHORIZED SERVICE CENTER FOR EVALUATION AND REPAIR.